

3K8/60
3K10/60
3K13/60

Caractéristiques Technical data	3K8/60	3K10/60	3K13/60
Chambre de broyage (mm) Shredding chamber (mm)	750x760	1000x760	1250x760
Lames de 30 mm (u) 30 mm blades (no.)	37	49	61
Lames de 50 mm (u) 50 mm blades (no.)	22	30	37
Puissance électrique (kW) Power (kW)	44	44	44
Tension (V) Voltage (V)	220/400/460	220/400/460	220/400/460
Poids (kg) Weight (kg)	6700	6900	7150

Des entraînements hydrauliques peuvent être installés pour le broyage de déchets particulièrement lourds.
For specifically heavy applications hydraulic drives can be installed.

Documentation Technique / Technical Data

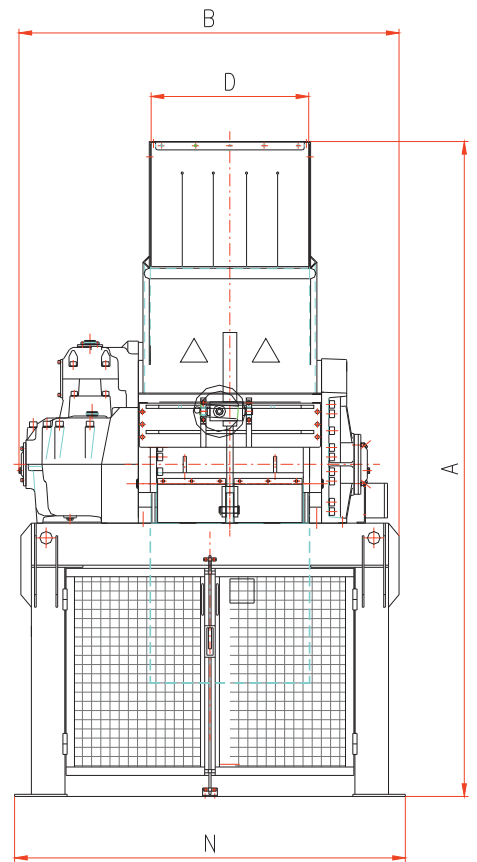
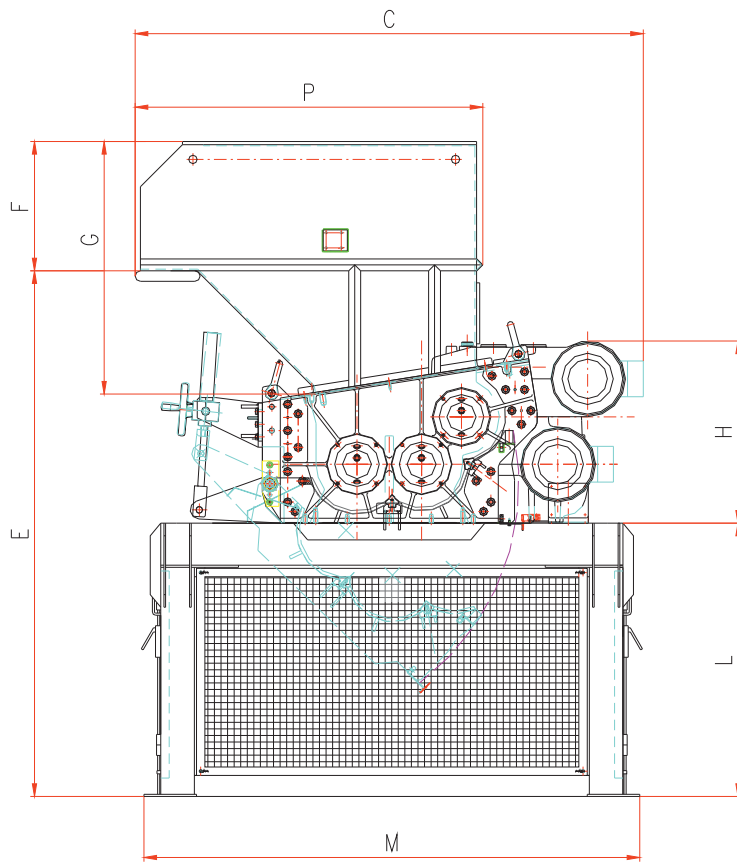

Déchets traités / Some applications:

Plastiques
Plastics



1 ÷ 1,5 t/h

Bois
Wood



1 ÷ 1,5 t/h

	3K8/60	3K10/60	3K13/60
A	3115	3115	3115
B	1810	2060	2420
C	2420	2420	2420
D	750	1000	1250
E	2500	2500	2500
F	615	615	615
G	1200	1200	1200
H	865	865	865
L	1300	1300	1300
M	2360	2360	2360
N	1860	2110	2360
P	1655	1655	1655

CAT1015 Rev. A 04/15

SatrindTech S.r.l.

Via Monfalcone, 122 - 20010, Arluno (MI) - Italie
Tel. (+39) 02 90 37 66 83

sales@satrindtech.com
satrindtech.com

SatrindTech France - Groupe SEREX

19, chemin de la Violette, 31240 L'Union - France
Tel. (+33) 05 62 89 08 88

contact@satrindtech-france.fr
www.satrindtech-france.fr

